

Phone (407)302-8602
Fax (407)402-8408
owensdistributors@gmail.com
Receive free freight on orders
over \$2000.00



ROYAL SERIES PLUMBING DECK MOUNT PRE-RINSE

MODEL: **17-202W**

PRODUCT IMAGE



17-202W SHOWN

**ALSO AVAILABLE IN LOW LEAD BY
ADDING "L" TO MODEL NUMBER**

STANDARD FEATURES

- 1/4 turn high performance ceramic cartridge valve with built-in back flow preventers
- Base constructed of chrome plated brass
- Pre-assembled at factory to cut installation time
- 44" heavy-duty stainless steel clad flexible hose. Tested to 400 PSI
- Wall bracket included
- Full replacement parts available
- 1 Year Warranty
- Mounting kit included
- **Low Lead Compliance**
"L" Models meet California AB-1953 and Vermont S152 standards

SPECIFICATIONS

- Single hole deck mount with 1/2" NPT male inlet
- 1 1/8" OD x 2 1/4" shank
- 38" high with 15" overhang
- Riser Pipe with Hook: 3/8" NPT x 18". Pre-assembled to base at factory
- Water Saver Spray Head: 1 1/2 GPM @ 60 PSI flow rate complies with EPA Act 2005
- Rough in: Single 1 1/8" round hole
- Temperature Range: 40°F to 180°F
- Flow rate: 2 GPM max
- Shipping weight: 13 lbs.
- Quantity per case: 3



ROYAL SERIES PLUMBING DECK MOUNT PRE-RINSE

MODEL: **17-202W** PROJECT: _____ ITEM#: _____ QTY: _____

DRAWING

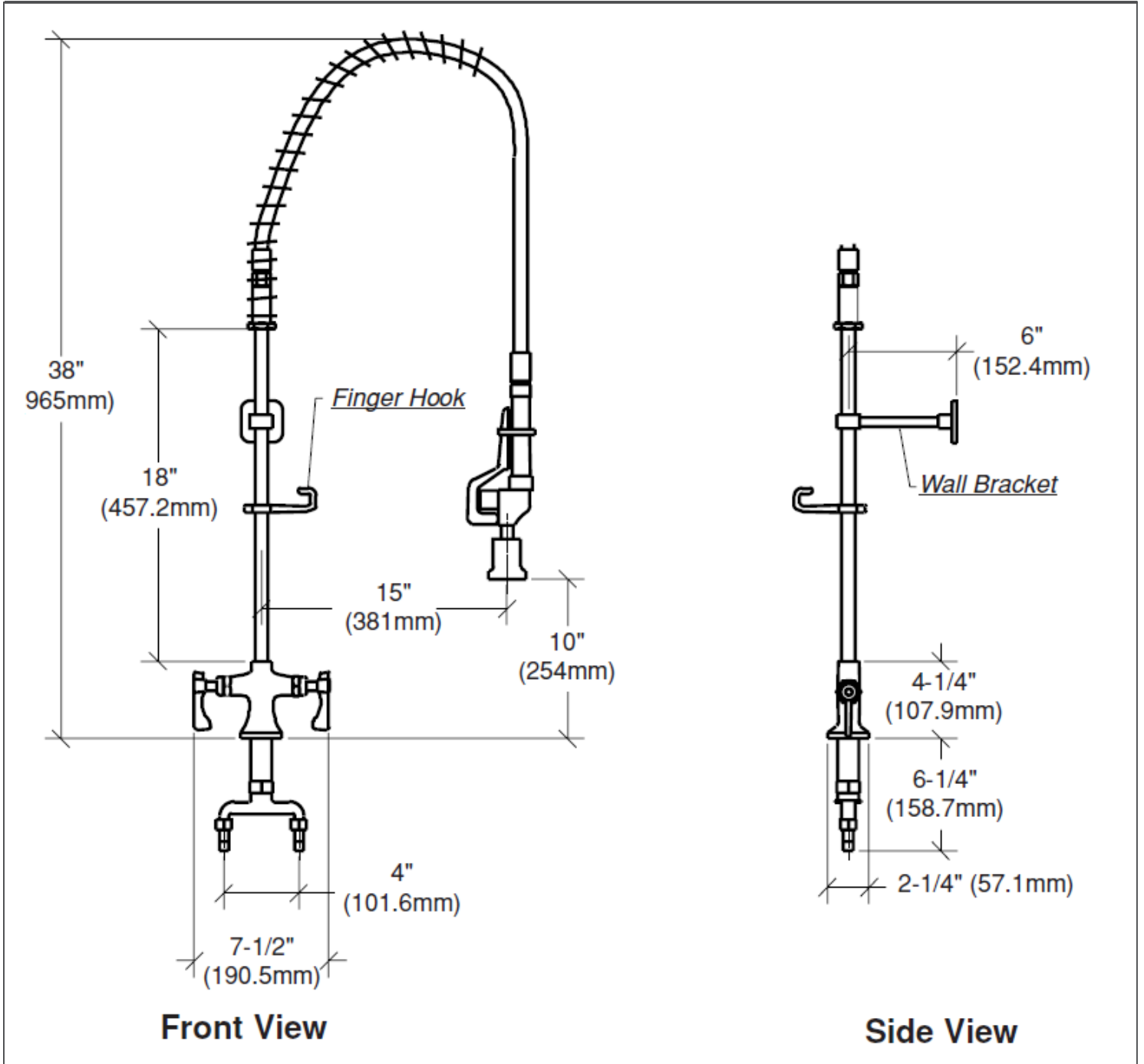

CERTIFICATIONS:

APPROVED BY:

Due to our commitment to continued product improvement, specifications are subject to change without notice.